

H3522SN03 (JP/22H-03)

A

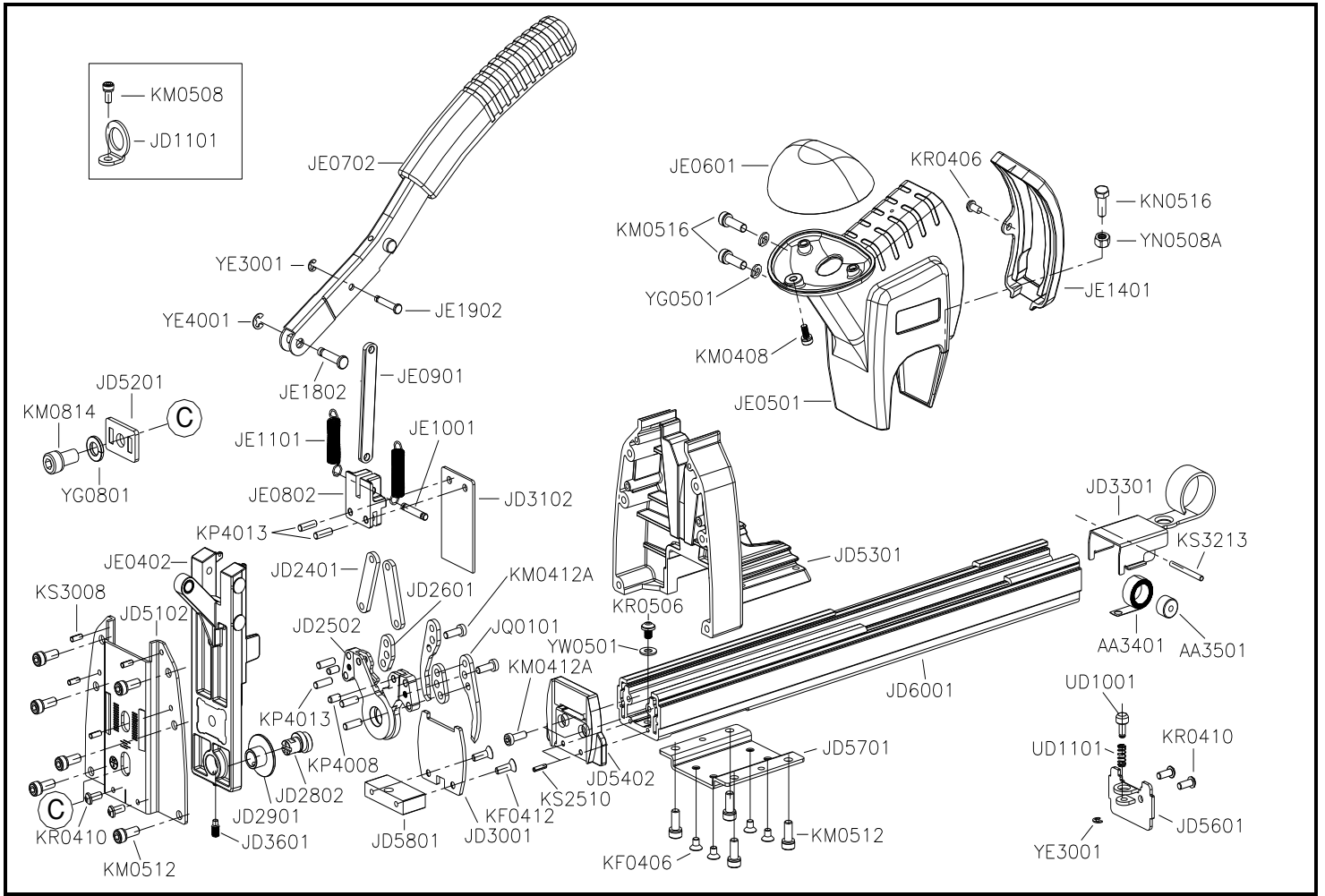

Part_No	Description	Spec	Q'ty	Part_No	Description	Spec	Q'ty	Part_No	Description	Spec	Q'ty
AA3401	PUSHER SPRING		1	JE0601	HANDLE		1	KR0410	BUTTON HD.BOLT	M4×0.7—10L	4
AA3501	ROLLER		1	JE0702	HANDLE UNIT		1	KR0506	BUTTON HD.BOLT	M5×0.8—06L	1
JD1101	HANGER		1	JE0802	ADJUSTABLE SEAT		1	KS2510	SPRING PIN	∅ 2.5-10L	2
JD2401	LINK		2	JE0901	LINK		1	KS3008	SPRING PIN	∅ 3-8L	4
JD2502	ANVIL HOLDER		2	JE1001	PIN		1	KS3213	SPRING PIN	∅ 1/8"×1/2L	1
JD2601	SPACER		2	JE1101	PULL SPRING		2	UD1001	STOP PIN		1
JD2802	PENETRATION ECCENTRIC		1	JE1401	GUIDE COVER		1	UD1101	COMPRESSION SPRING		1
JD2901	BUSHING		1	JE1802	PIN		1	YE3001	E-RING	∅ 3.0	2
JD3001	COVER PLATE		1	JE1902	PIN		1	YE4001	E-RING	∅ 4.0	1
JD3102	DRIVER		1	JQ0101	ANVIL HOOK		2	YG0501	SPRING WASHER	∅ 5	2
JD3301	PUSHER		1	KF0406	FLAT HD.BOLT	M4×0.7—6L	4	YG0801	SPRING WASHER	∅ 8	1
JD3601	RETAINER SCREW		1	KF0412	FLAT HD.BOLT	M4×0.7—12L	2	YN0508A	HEX.NUT	M5×0.8(T=2.7mm)	1
JD5102	FRONT SECTION		1	KM0408	HEX.SOC.HD.BOLT	M4×0.7—8L	1	YW0501	FLAT WASHER	∅ 5	1
JD5201	ADJUST SUPPORT		1	KM0412A	HEX.SOC.HD.BOLT	M4×0.7—12L	4				
JD5301	REAR BODY		1	KM0508	HEX.SOC.HD.BOLT	M5×0.8—8L	1				
JD5402	GUIDE PLATE		1	KM0512	HEX.SOC.HD.BOLT	M5×0.8—12L	10				
JD5601	STOP PLATE		1	KM0516	HEX.SOC.HD.BOLT	M5×0.8—16L	2				
JD5701	CONNECT SET		1	KM0814	HEX.SOC.HD.BOLT	M8×1.25—14L	1				
JD5801	DISTANCE SET		1	KN0516	HEX.SOC.HD.BOLT	M5×0.8—16L	1				
JD6001	MAGAZINE SEAT		1	KP4008	PARALLEL PIN	∅ 4×8L	2				
JE0402	BODY(2)		1	KP4013	PARALLEL PIN	∅ 4×13L	6				
JE0501	BODY(1)		1	KR0406	BUTTON HD.BOLT	M4×0.7—6L	1				

★☆ If you need to order parts, please mark both Parts No. and Description. ☆★